



Vardar Dolomit

About VARDAR DOLOMIT

- **An independent European manufacturer** of **sinter dolomite**, **dolomite bricks** and **monolithics** located in Gostivar, Macedonia (70 km from Skopje)
- **Acquired by Haznedar Group in 2003**; two sister companies: **Haznedar Refractories** & **Durer Monolithics** located in Istanbul
- **Integrated production system** with direct access & control of its raw material through the **high-grade dolomite mines owned by the company**
- **Manufacturing capacity of 60.000 tons a year**
- Usage of the **purest dolomite raw material in Europe**, **Impurity \leq % 1,5**
- **ISO 9001 Quality Management System certificate**
- **ISO 14001 Environmental Management System certificate**
- **ISO 50001 Energy Management System certificate**



About HAZNEDAR REFRACTORIES

- Global supplier of high-grade refractory bricks and solutions for **over four continents**
- **250 skilled employees, manufacturing capacity over 80,000 tons a year**
- **Extensive line of alumina and basic products for a wide variety of industrial furnaces and other processing units**
- **First and only Turkish refractory company that has made an investment abroad**
- Superior product performance, immediate service & long history of expertise
- **ISO 9001 Quality Management System certificate**



History of HAZNEDAR GROUP

1929

Haznedar Refractories is founded in Istanbul, Turkey with the goal of manufacturing building bricks & tiles for the construction industry.



1952

Haznedar Refractories is acquired by its current stakeholders and adopted the new strategy of becoming the nation's highest quality supplier of refractory products.



1977

Haznedar's sister company Monolithics is established for the specialized production of unshaped refractories.



2000

Haznedar and Durer invested on the construction of a new plant with a total manufacturing capacity over 125.000 tons a year on a 85.000 m² land just outside of Istanbul.

2003

Haznedar Group acquired Vardar Dolomit plant and its adjacent mines in Gostivar, Macedonia.

A new expansion policy on exports is put into effect and the future plans were shaped accordingly.



1933

Together with the boom of the industrialization period in Turkey, Haznedar Refractory commenced the production of fireclay refractories to be used in furnace linings.



1967

Haznedar Refractories Bahçelievler plant underwent modernization to enhance the quality and volume of its production.



1997

Haznedar Refractories acquired the ISO 9001 Quality Management System Certification.



2001

The new plant started the refractory production in Çerkezköy.



2013-present

More than 50% of Haznedar's production is directed to exports over four continents.

About DURER MONOLITHICS

- Manufacturing and servicing of **monolithic refractories** with **four decades of experience**
- **Immediate response to the changing demands of the industrial market through technical innovations and problem solving design**
- **Manufacturing capacity of 50,000 tons a year & plant equipped with the latest technology**
- Right lining equipment and right solutions



Vision of HAZNEDAR GROUP

• Haznedar Group works towards delivering the best value for all of its stakeholders. **Being responsive and responsible to all of the stakeholders namely: our customer, employees, suppliers, stockholders, community and environment is the foundation principle of our company.**

• Haznedar Group is **committed to the safety and wellbeing of its workforce.** We take all necessary measures to eliminate risks in our work field and have each of our employees' health monitored annually.

• Haznedar Group aims to exceed the expectations of our customers through the **prompt supply of high quality, innovative products and solutions** to enhance their own productivity and efficiency.

• Haznedar Group's relationship with its suppliers is central to its manufacturing of the highest quality products. **We choose our partners based on their reliability, quality, fairness and sustainability.** We aspire to maintain mutual and long lasting rapport within our partnerships.

• Haznedar Group keeps ahead of its competitors through its **dedication to research and development** and instantaneously responds to the changing demands of the domestic and global markets.

• Haznedar Group takes all the initiatives to **make its business more sustainable with minimum impact on the environment**

Haznedar Group acknowledges the **importance of raising communities and support the education of its local society.**

- Consultation
- Project Engineering
- Installation
- Supervision
- Dry Out
- Maintenance



Iron & steel industry consumes close to %75 of the refractories manufactured around the globe. The consumption speed of refractories in the iron& steel industry is very high. In regards to global consumption figures of refractories, total refractory material consumption of the sector is calculated to be 10 kg per ton of liquid steel manufactured. This figure may shift up and down depending on each country. It is possible to measure the performance life of refractories both in years (ex: ladle bricks) and in days (ex: blast furnace bricks) depending on the unit processors they are used at. Refractory products with very diverse characteristics and structures are being used during the steel production process taking place in integrated and mini mill plants alike. These products may be refractory bricks of various shapes and dimensions as well as castables with alumina silicate or basic material based.

Dolomite is a cost effective alternative to magnesia carbon refractories and yield to higher number of heats, especially for the si-killed steel production. The lower carbon content of doloma products enable cleaner steel production. Their lower thermal conductivity also make dolomite a better option in preventing the heat loss of ladles. Shipped in sets, dolomite bricks require lower storage costs for leftover bricks.

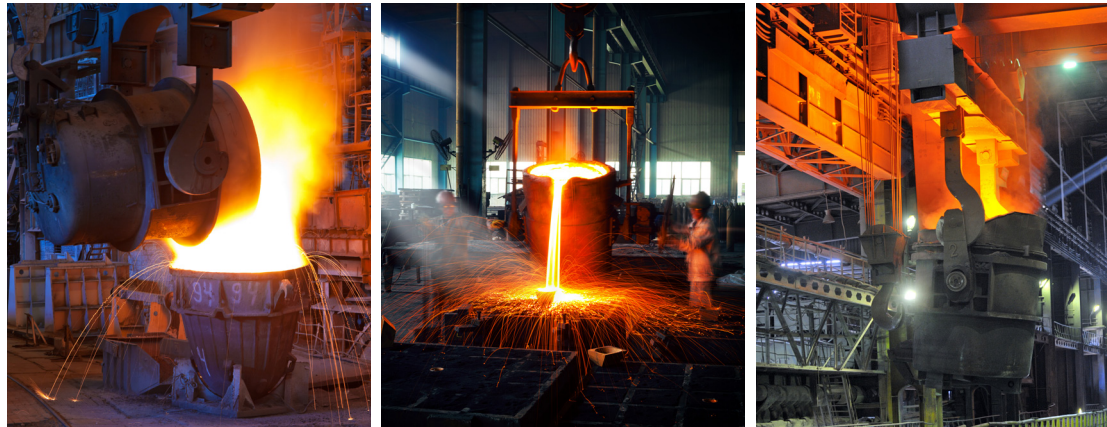

Why Dolomite for the Iron & Steel Industry?

Dolomite usage in steelmaking industry has been rapidly increasing in the past decades as a result of its favorability in the making of clean steel with clean environment. Dolomites'

- **high degree of refractoriness,**
- **inertness to steel,**
- **great service performance,**
- **low cost**

make it a more conscious and reasonable preference for the steelmakers of the 21st century.

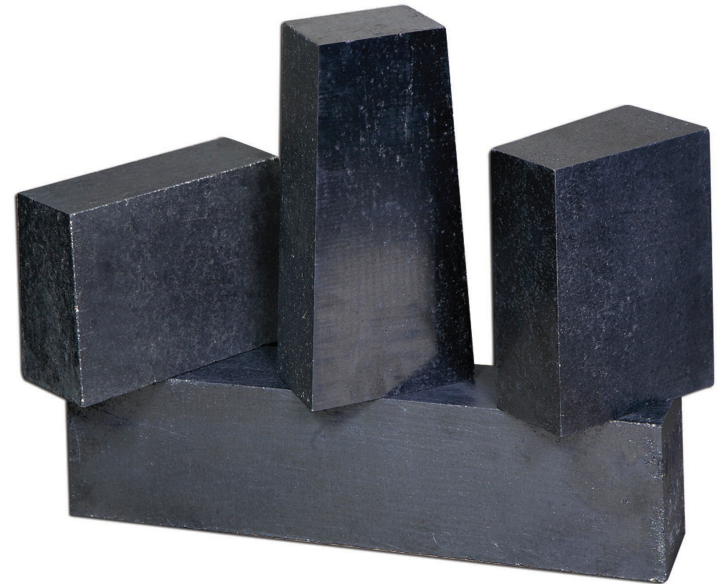

The Advantages of Doloma Usage vs. Magnesia Carbon Bricks

- Dolomite is a **cost-effective alternative** to Magnesia Carbon
- Dolomite yields to **a higher number of heats** especially for Si-killed steel production
- The lower Carbon content of doloma products enable **cleaner steel production**
- Shipped in sets, dolomite bricks **require lower storage costs** for leftover bricks
- As the density of dolomite bricks are lower than that of Magnesia Carbon products, when compared to the same volume of MgC bricks, dolomite bricks contain **less amount of material**. In one ladle this difference may result in a variance of 2500 to 3000 kg depending on ladle size
- Dolomite bricks are a **better option to prevent heat loss** in ladles through its lower thermal conductivity rate compared to MgC bricks



VARDAR DOLOMITE Products for Ladles

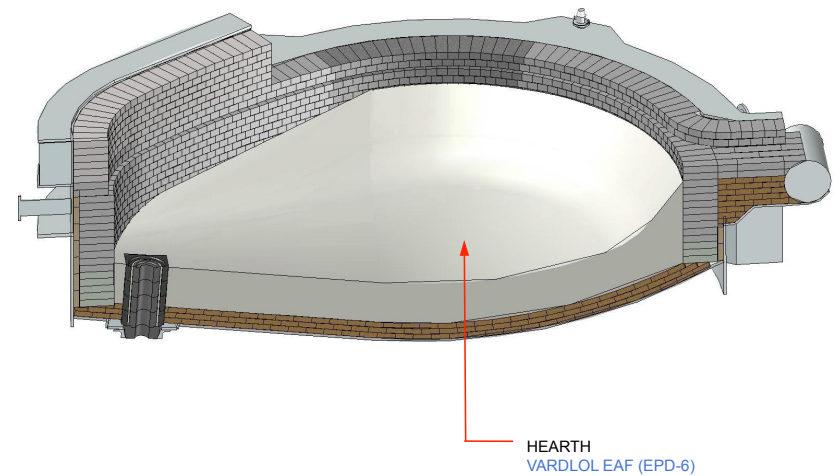
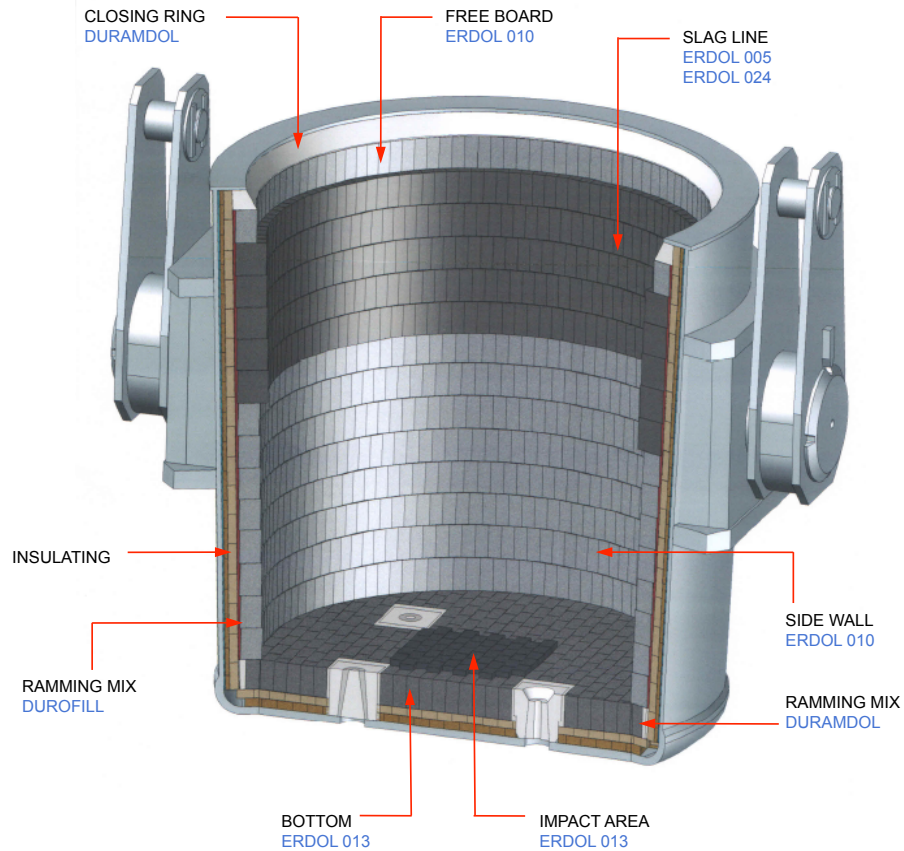

Production Flow Diagram

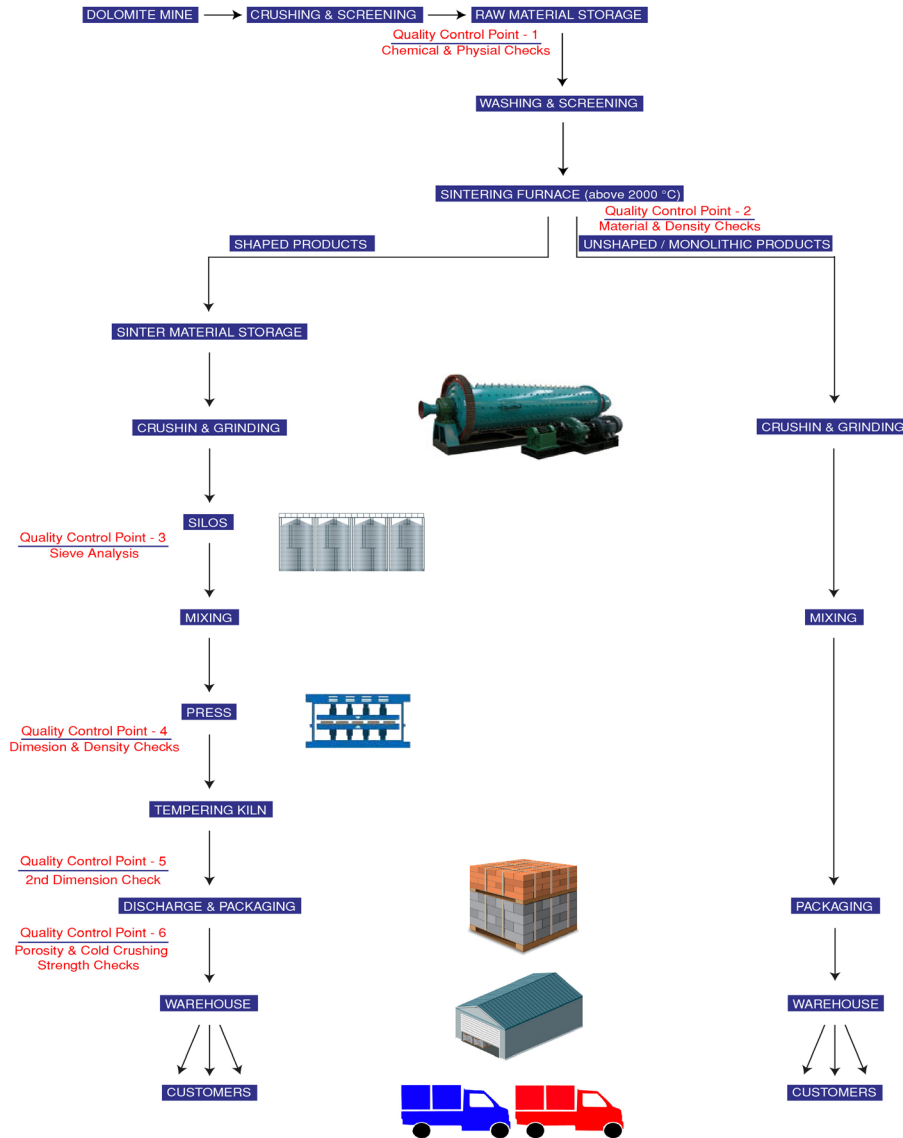

RESIN BONDED DOLOMITE-CARBON BRICKS

Product Name	Chemical Analysis						Physical Properties		
	MgO	CaO	SiO ₂	Al ₂ O ₃	Fe ₂ O ₃	C	Bulk Density	APP Porosity	C.C.Strenght
							g/cm ³	vol. %	kg/cm ²
ERDOL 005 R	39	59	0,5	0,5	0,5	9	2,75	10,5	65
ERDOL 010 R	39	59	0,5	0,5	0,5	5	2,80	9,7	75
ERDOL 013 R	39	59	0,5	0,5	0,5	6	2,80	9,8	70
ERDOL 021 R	45	52	0,5	0,5	0,5	4	2,82	9,0	80
ERDOL 024 R	52	45	0,5	0,5	0,5	8	2,83	9,3	75

ECO - PITCH BONDED DOLOMITE-CARBON BRICKS

Product Name	Chemical Analysis						Physical Properties		
	MgO	CaO	SiO ₂	Al ₂ O ₃	Fe ₂ O ₃	C	Bulk Density	APP Porosity	C.C.Strenght
							g/cm ³	vol. %	kg/cm ²
ERDOL 005	39	59	0,5	0,5	0,5	9	2,70	11,0	35
ERDOL 010	39	59	0,5	0,5	0,5	5	2,75	10,0	40
ERDOL 013	39	59	0,5	0,5	0,5	6	2,75	10,2	40
ERDOL 021	45	52	0,5	0,5	0,5	4	2,77	9,6	50
ERDOL 024	52	45	0,5	0,5	0,5	8	2,78	9,7	45

DOLOMITE MIXES

Product Name	Chemical Analysis						Physical Properties	
	MgO	CaO	SiO ₂	Al ₂ O ₃	Fe ₂ O ₃	Cg	Bulk Density g/cm ³	APP Porosity vol. %
DUROFIL	38	60	0,5	0,5	0,5	-	2,45	0-6
DURAMDOL	38	60	0,5	0,5	0,5	-	2,8	0-8
WARDOL EAF (EPD-6)	38	60	0,5	0,5	0,5	6	2,1-2,2	0-6
WARDOL MIX (Plastic)	50	48	0,5	0,5	0,5	-	2,8	0-3

Standard Brick Shapes

LADLE BRICKS P - FORMAT

Shape	Dimensions (mm)					Volume dm ³	Radius r (mm)
	a	b	h	l	k (a-b)		
1P 0	125	125	90	250		2,81	
1P 8	129	121	90	250	8	2,81	1.384
1P 18	134	116	90	250	18	2,81	590
1P 26	138	112	90	250	26	2,81	395
1P 37	143	106	90	250	37	2,80	263
1P 8-2/3	86	78	90	250	8	1,85	
1P 8-3/4	97	89	90	250	8	2,09	
2P 0	125	125	124	250		3,88	
2P 10	130	120	124	250	10	3,88	1.513
2P 24	137	113	124	250	24	3,88	594
2P 10-2/3	87	77	124	250	10	2,54	
2P 10-3/4	98	88	124	250	10	2,88	
3P 0	100	100	155	250		3,88	
3P 8	104	96	155	250	8	3,88	1.899
3P 10	105	95	155	250	10	3,88	1.504
3P 20	110	90	155	250	20	3,88	713
3P 26	113	87	155	250	26	3,88	525
3P 10-2/3	70	60	155	250	10	2,52	
3P 10-3/4	79	69	155	250	10	2,87	

Shape	Dimensions (mm)					Volume dm ³	Radius r (mm)
	a	b	h	l	k (a-b)		
4P 0	100	100	187	250		4,68	
4P 8	104	96	187	250	8	4,68	
4P 12	106	94	187	250	12	4,68	
4P 22	111	89	187	250	22	4,68	
4P 12-2/3	71	59	187	250	12	3,04	
4P 12-3/4	80	68	187	250	12	3,46	
5P 0	100	100	220	250		5,50	
5P 8	104	96	220	250	8	5,50	2.695
5P 16	108	92	220	250	16	5,50	1.293
5P 22	111	89	220	250	22	5,50	8
5P16-2/3	72	56	220	250	16	3,52	
5P 16-3/4	81	65	220	250	16	4,02	

LADLE BRICKS SEMI UNIVERSAL

Shape	Dimensions (mm)				Volume dm ³	Radius D (mm)
	a	b	h	l		
S U 430	210	188,7	101,6	100	2,03	1500 - 2500
S U 445	210	195,8	101,6	100	2,06	2100 - 3400
S U 530	210	183,4	127	100	2,50	1500 - 2500
S U 545	210	192,3	127	100	2,55	2100 - 3400
S U 560	210	196,7	127	100	2,58	2800 - 4500
S U 630	210	178,1	152,4	100	2,96	1500 - 2500
S U 645	210	188,7	152,4	100	3,04	2100 - 3400
S U 660	210	194	152,4	100	3,08	2800 - 4500
S U 745	210	185,2	177,8	100	3,51	2100 - 3400
S U 760	210	191,4	177,8	100	3,57	2800 - 4500
S U 830	210	168	203,2	100	3,78	1500 - 2500
S U 845	210	181,6	203,2	100	3,98	2400 - 3600
S U 860	210	188,7	203,2	100	4,05	3400 - 4600
S U 930	210	163	228,6	100	4,20	1500 - 2500
S U 945	210	178,1	228,6	100	4,44	2100 - 3400
S U 960	210	186,1	228,6	100	4,53	2800 - 4500

LADLE BRICKS RADIAL KEY

Shape	Dimensions (mm)					Volume dm ³	Radius r (mm)
	a	b	h	l	k(a-b)		
12/11 - 10	211	200	125	100	11	2,57	2282
12/21 - 10	221	200	125	100	21	2,63	1207
12/33 - 10	233	200	125	100	33	2,71	784
12/50 - 10	250	200	125	100	50	2,81	539
15/13 - 10	213	200	150	100	13	3,10	2308
15/25 - 10	225	200	150	100	25	3,19	1200
15/40 - 10	240	200	150	100	40	3,30	750
15/60 - 10	260	200	150	100	60	3,45	540
18/16 - 10	216	200	180	100	16	3,74	2250
18/30 - 10	230	200	180	100	30	3,87	1200
18/48 - 10	248	200	180	100	48	4,03	750
18/72 - 10	272	200	180	100	72	4,25	540
22/19 - 10	219	200	220	100	19	4,61	2300
22/37 - 10	237	200	220	100	37	4,81	1200
22/59 - 10	259	200	220	100	59	5,05	750
22/16 - 10	216	200	250	100	16	5,20	3131
25/30 - 10	230	200	250	100	30	5,38	1670
25/16 - 10_2/3	149	133	250	100	16	3,53	2087
25/30 - 10_2/3	163	133	250	100	30	3,71	119
25/16 - 10_3/4	166	150	250	100	16	3,95	2348
25/30 - 10_3/4	180	150	250	100	30	4,13	1258

Standard Brick Shapes

LADLE BRICKS MINI KEY

Shape	Dimensions (mm)					Volume dm ³	Radius r (mm)
	a	b	h	l	k (a-b)		
MK 4/0	150	150	101,6	100	0	1,52	
MK 4/6	153	147	101,6	100	6	1,52	2496
MK 4/12	156	144	101,6	100	12	1,52	1229
MK 4/20	160	140	101,6	100	20	1,52	726
MK 5/0	150	150	127	100	0	1,91	
MK 5/8	154	146	127	100	8	1,91	2324
MK 5,20	160	140	127	100	20	1,91	901
MK 5/32	166	134	127	100	32	1,91	549
MK 5/20 K	130	110	127	100	20	1,52	708
120 6/0	150	150	152,4	100	0	2,29	
MK 6/8	154	146	152,4	100	8	2,29	2787
MK 6/13	157	144	152,4	100	13	2,29	1696
MK 6/20	160	140	152,4	100	20	2,29	1077
MK 6/30	165	135	152,4	100	30	2,29	700
MK 6/40	170	130	152,4	100	40	2,29	513
MK 6/20 K	130	110	152,4	100	20	1,83	846
120 7/0	150	150	177,8	100	0	2,67	
MK 7/8	154	146	177,8	100	8	2,67	3251
MK 7/13	157	144	177,8	100	13	2,68	1976
MK 7/16	158	142	177,8	100	16	2,67	1586
MK 7/20	160	140	177,8	100	20	2,67	1254
MK 7/30	165	135	177,8	100	30	2,67	812
MK 7/40	170	130	177,8	100	40	2,67	593
MK 7/20 K	130	110	177,8	100	20	2,13	985

Shape	Dimensions (mm)					Volume dm ³	Radius r (mm)
	a	b	h	l	k (a-b)		
120 8/0	150	150	203,2	100	0	3,05	
MK 8/8	154	146	203,2	100	8	3,05	3714
MK 8/16	157	144	203,2	100	16	3,05	1836
MK 8/20	160	140	203,2	100	20	3,05	1431
MK 8/30	165	135	203,2	100	30	3,05	925
MK 8/40	170	130	203,2	100	40	3,05	674
MK 9/0	150	150	228,6	100	0	3,43	4178
MK 9/8	154	146	228,6	100	8	3,43	2064
MK 9/16	157	144	228,6	100	16	3,43	1039
MK 9/30	165	135	228,6	100	30	3,43	755
MK 9/40	170	130	228,6	100	40	3,43	586
MK 9/50	175	125	228,6	100	50	3,43	
25/0	150	150	250	100	0	3,75	4569
25/8	154	146	250	100	8	3,75	2225
25/16	158	142	250	100	16	3,75	1134
25/30	165	135	250	100	30	3,75	515
25/60	180	120	250	100	60	3,75	
30/0	150	150	300	100	0	4,50	5481
30/8	154	146	300	100	8	4,50	2107
30/20	160	140	300	100	20	4,50	985
30/40	170	130	300	100	40	4,50	507
30/70	185	115	300	100	70	4,50	

Ladle Heat Up Schedule for Dolomite Lining

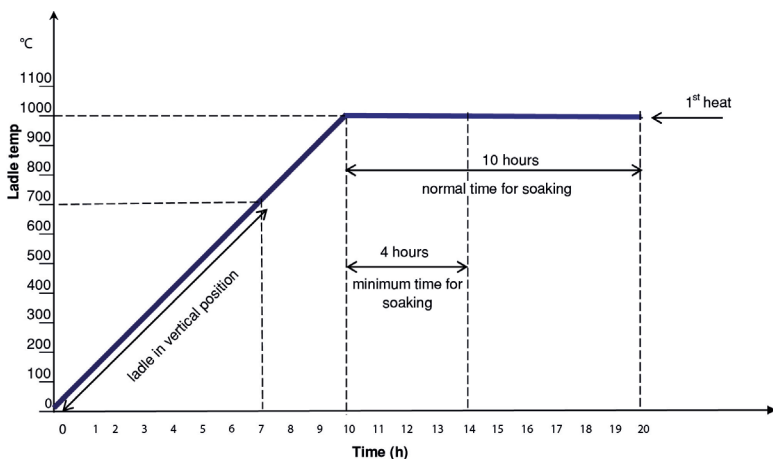

LADLE PRE-HEATING CURVE

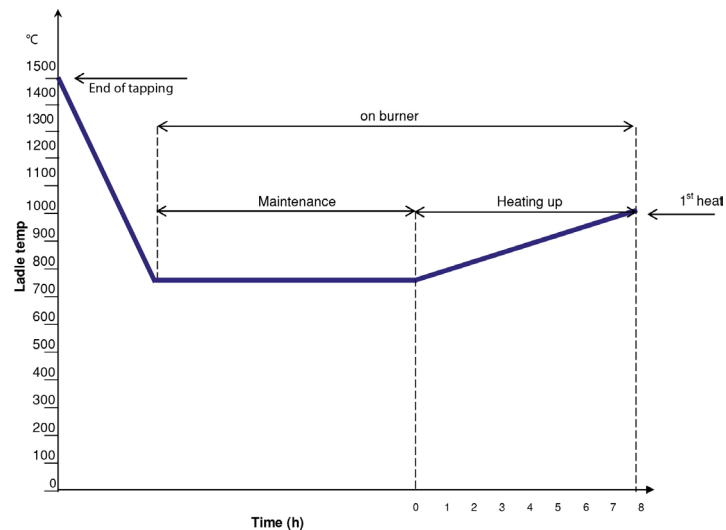

LADLE MAINTENANCE CURVE

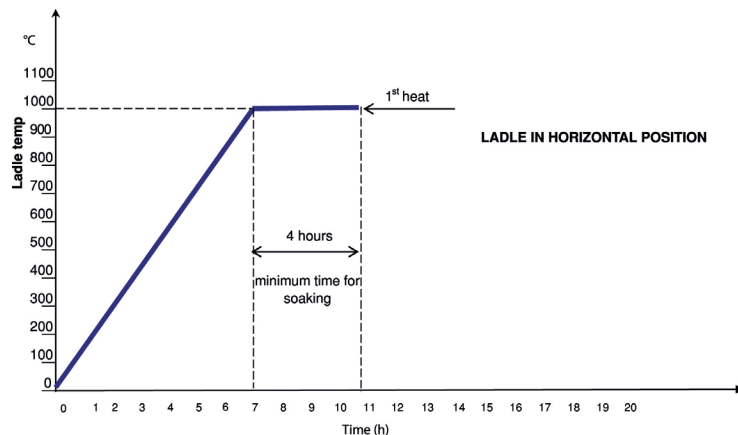

LADLE RE-HEATING CURVE

Customer Network

Our presence in Turkey

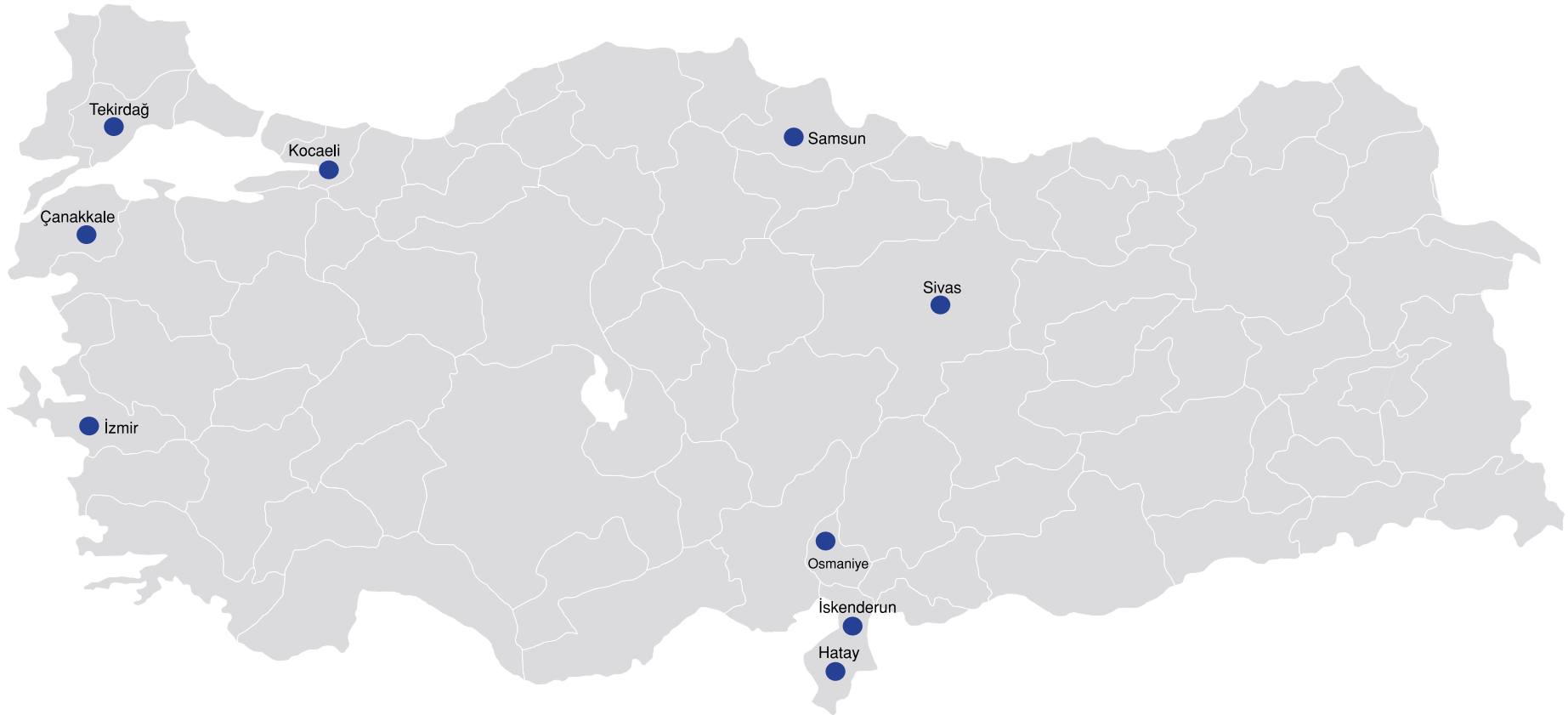

Customer Network Our International Presence

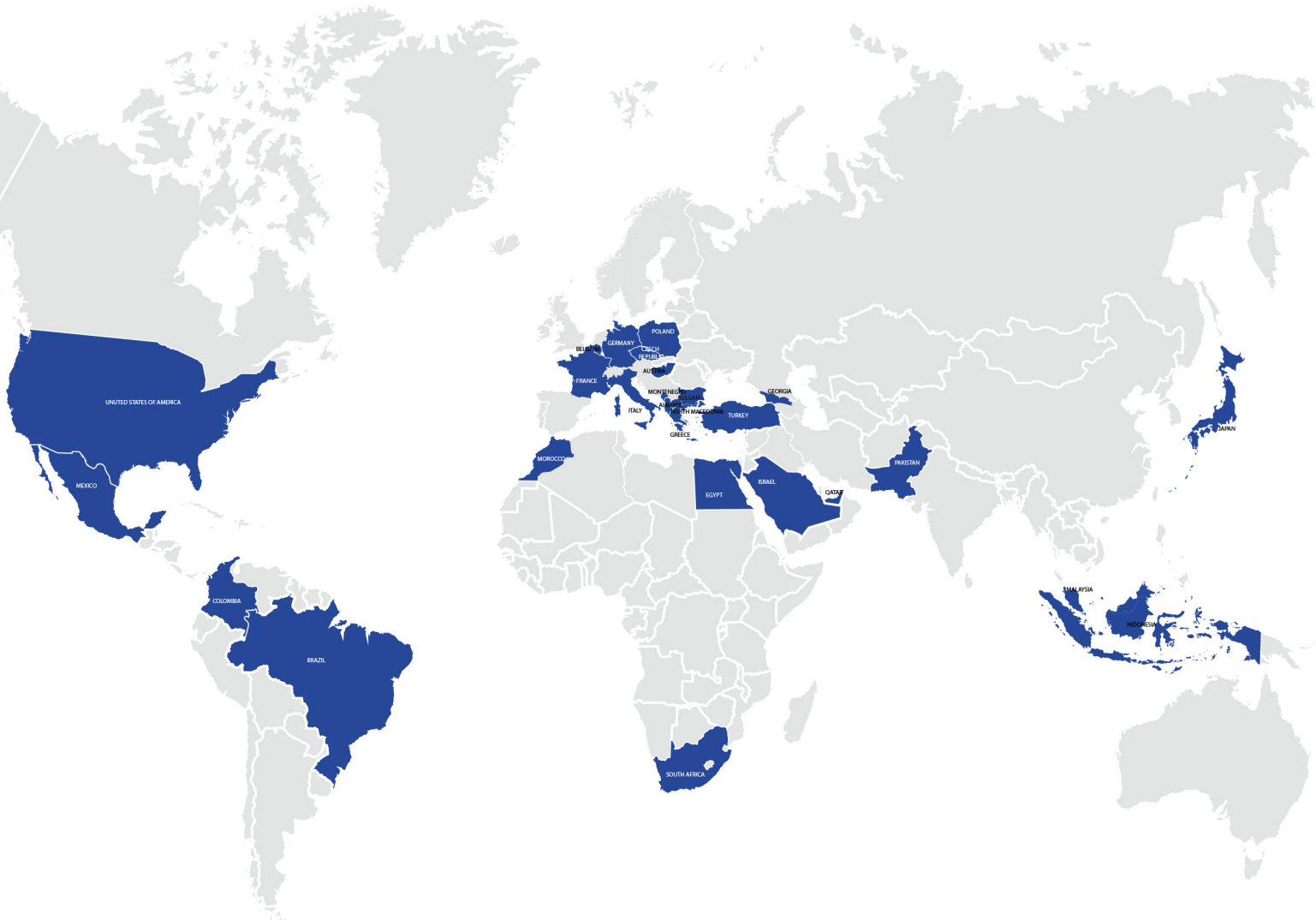

● IRON & STEEL PRODUCTION

VARDAR DOLOMITE Packaging

- Dolomite has a high tendency to hydrate and react with atmospheric dampness. Yet, if packaged effectively and all necessary precautions are taken, dolomite may be used around the world without any difficulties.
- “Vardar Dolomit products are to be shipped globally to far away locations such as United States, Japan and South Africa. Acknowledging dolomites’ susceptibility to atmospheric moisture and hydration tendency, Vardar commits to delivering its materials to each destination at its perfect condition. Dolomite pallets, which are stored in dry atmospheres without any damage to the packaging, may stay intact for about 6 months long.

Vardar practices two separate versions of packaging depending on the vicinity of customers and pays the utmost attention to avoid waste of packaging and labor force.

Important factors that are highly considered in the elimination of unnecessary packaging are minimizing our carbon footprint, protecting the environment and rightfully employing the precepts of our ISO 14001 Environmental Management System Certificate.”



ISO 9001 Quality Management System Certificate

Certificate of Registration

QUALITY MANAGEMENT SYSTEM - ISO 9001:2015

This is to certify that:

Vardar Dolomit DOOEL U.I.J.N.A. Br.318 Gostivar 1230 Macedonia	Vardar Dolomit DOOEL U.I.J.N.A. Br.318 Gostivar 1230 Macedonia
--	--

Holds Certificate No: **FM 504509**

and operates a Quality Management System which complies with the requirements of ISO 9001:2015 for the following scope:

Production and delivery of sinter dolomite, dolomite masses and shaped dolomite products.

For and on behalf of BSI:

Andrew Launn, EMEA Systems Certification Director

Original Registration Date: 2006-02-15
Latest Revision Date: 2017-12-19

Effective Date: 2017-12-25
Expiry Date: 2020-12-24

Page: 1 of 1

...making excellence a habit™

This certificate was issued electronically and remains the property of BSI and is bound by the conditions of contract. An electronic certificate can be authenticated [online](#). Printed copies can be validated at www.bsi-global.com/ClientDirectory or telephone +971 (4) 3364917.

Information and Contact: BSI, Kitemark Court, Davy Avenue, Knowlhill, Milton Keynes MK5 8PP. Tel: + 44 345 080 9000
BSI Assurance UK Limited, registered in England under number 7805321 at 389 Chiswick High Road, London W4 4AL, UK.

ISO 14001 Environmental Management System Certificate

Certificate of Registration

ENVIRONMENTAL MANAGEMENT SYSTEM - ISO 14001:2015

This is to certify that:

Vardar Dolomit DOOEL U.I.J.N.A. Br.318 Gostivar 1230 Macedonia	Vardar Dolomit DOOEL U.I.J.N.A. Br.318 Gostivar 1230 Macedonia
--	--

Holds Certificate No: **EMS 524809**

and operates an Environmental Management System which complies with the requirements of ISO 14001:2015 for the following scope:

Production and delivery of sinter dolomite, dolomite masses and shaped dolomite products.

For and on behalf of BSI:

Andrew Launn, EMEA Systems Certification Director

Original Registration Date: 2008-01-07
Latest Revision Date: 2017-12-19

Effective Date: 2017-01-07
Expiry Date: 2020-01-06

Page: 1 of 1

...making excellence a habit™

This certificate was issued electronically and remains the property of BSI and is bound by the conditions of contract. An electronic certificate can be authenticated [online](#). Printed copies can be validated at www.bsi-global.com/ClientDirectory or telephone +971 (4) 3364917.

Information and Contact: BSI, Kitemark Court, Davy Avenue, Knowlhill, Milton Keynes MK5 8PP. Tel: + 44 345 080 9000
BSI Assurance UK Limited, registered in England under number 7805321 at 389 Chiswick High Road, London W4 4AL, UK.

ISO 50001 Energy Management System Certificate

Certificate of Registration

ENERGY MANAGEMENT SYSTEM - ISO 50001:2011

This is to certify that:

Vardar Dolomit DOOEL U.I.J.N.A. Br.318 Gostivar 1230 Macedonia	Vardar Dolomit DOOEL U.I.J.N.A. Br.318 Gostivar 1230 Macedonia
--	--

Holds Certificate No: **ENMS 685986**

and operates an Energy Management System which complies with the requirements of ISO 50001:2011 for the following scope:

Production and delivery of sinter dolomite, dolomite masses and shaped dolomite products. Energy sources include electricity for production and delivery of sinter dolomite, dolomite masses and shaped dolomite products; heavy and light fuel oil for production of sinter dolomite; light fuel oil for tempering shaped dolomite products.

For and on behalf of BSI:

Andrew Launn, EMEA Systems Certification Director

Original Registration Date: 2018-01-22
Latest Revision Date: 2018-01-22

Effective Date: 2018-01-22
Expiry Date: 2021-01-21

Page: 1 of 1

...making excellence a habit™

This certificate was issued electronically and remains the property of BSI and is bound by the conditions of contract. An electronic certificate can be authenticated [online](#). Printed copies can be validated at www.bsi-global.com/ClientDirectory or telephone +971 (4) 3364917.

Information and Contact: BSI, Kitemark Court, Davy Avenue, Knowlhill, Milton Keynes MK5 8PP. Tel: + 44 345 080 9000
BSI Assurance UK Limited, registered in England under number 7805321 at 389 Chiswick High Road, London W4 4AL, UK.

Management & Sales

Büyükçavuşlu Mah. Çerkezköy

Cad. No: 587 Silivri, 34594

İstanbul/TÜRKİYE

+90 212 7453505 (10 Hat)

+90 212 7453515

Info@vardardolomit.com

Info@hazref.com

Production Plant

Ul. "JNA" No.318 1230 Gostivar

p.fax 210

+389 (0)42 219-030

+389 (0)42 242-507

info@vardardolomit.com.mk

Finance Department

VARDAR DOLOMIT DOOEL Bul.

Ilinden No.47/1/2 1000 Skopje

+38 923 11 88 25

maja@betaconsulting.com.mk

elizabeta@betaconsulting.com.mk

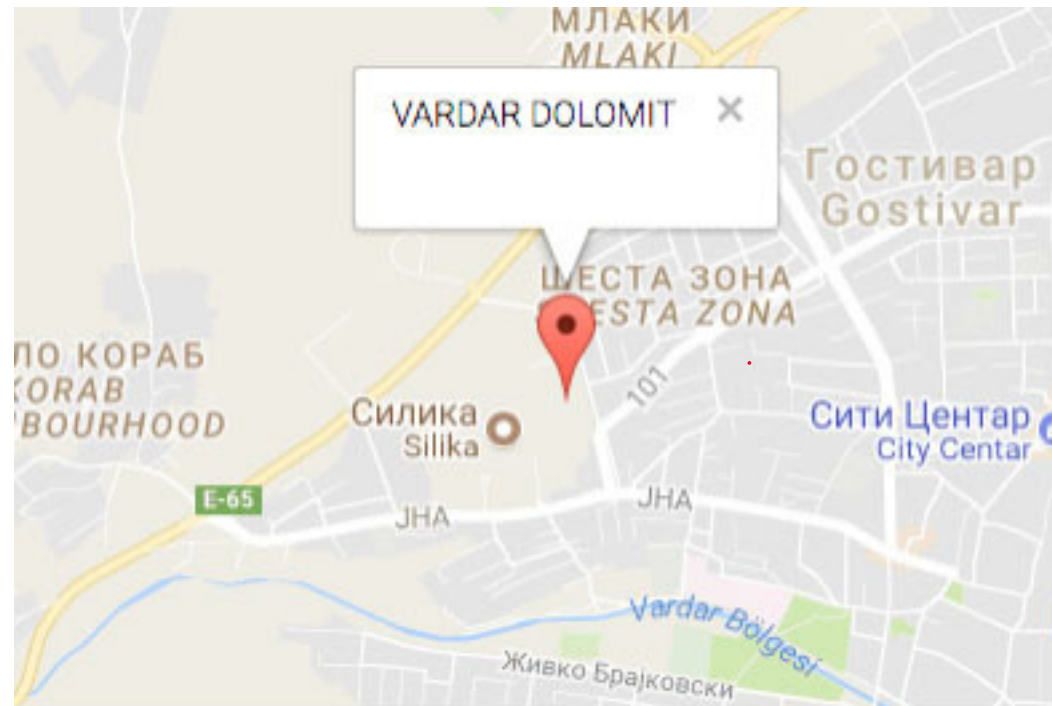

THANK YOU!

